

# All you need to know - Ullman Jockey seats

install - use - maintain

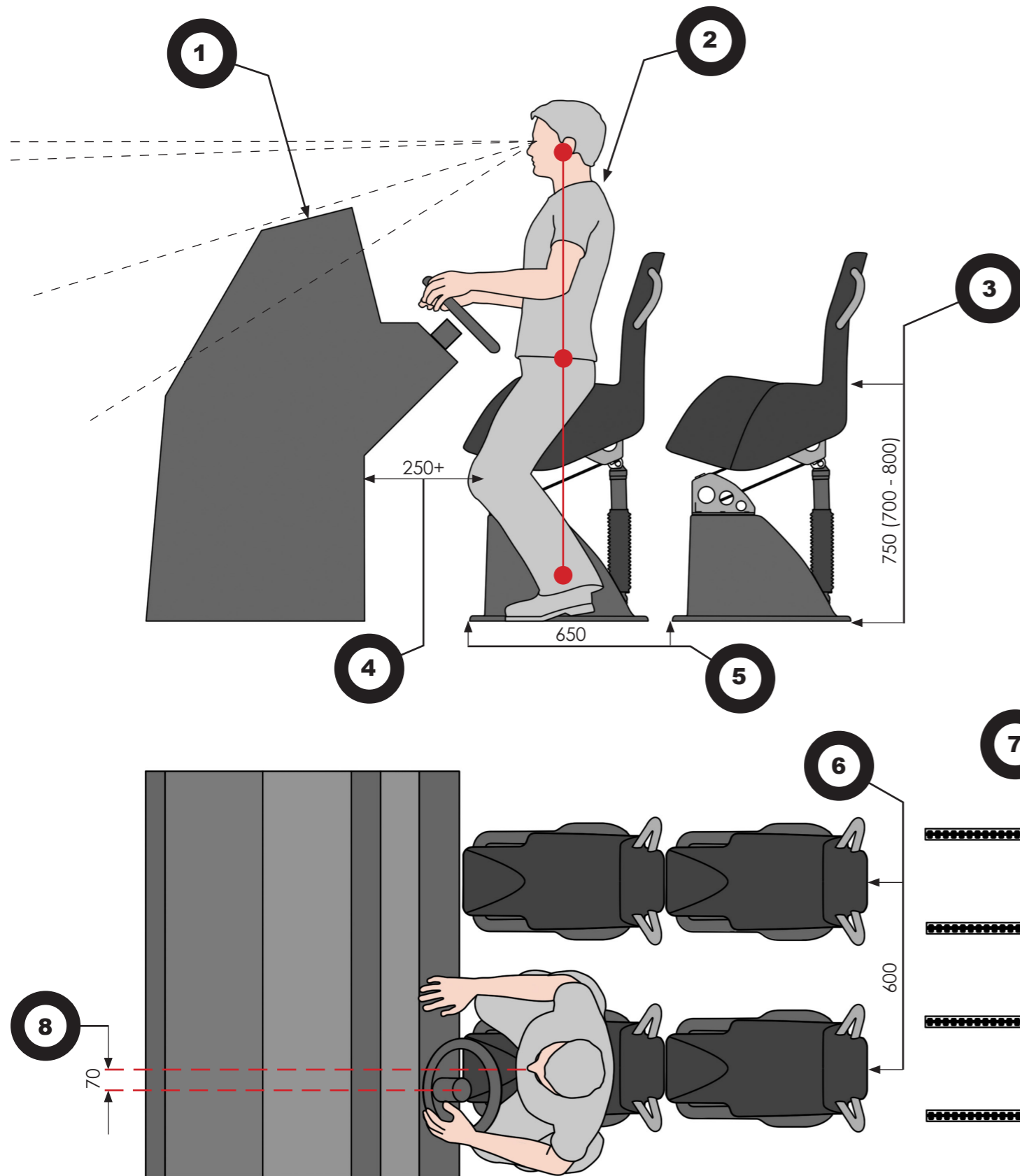

## 1: Console design

Aiming for the best console ergonomics? Visit [ullmandynamics.com](http://ullmandynamics.com) for full design guide lines.

## 2: Posture

Optimal seating posture is achieved with an upright forward facing position with the head, pelvis and feet aligned vertically.

## 3: Seating height

The Ullman Jockey are available in three stock heights. STD 750 mm (700 & 800). Always let the chosen seating height be driven by your platforms sight lines.

## 4: Knee Clearance

Recommended spacing between console and seat (front face of spring unit) = 250+ mm.

## 5: Seat layout - Longitudinal split

Recommended longitudinal seat c-c measure is 650-700 mm. (Min 560 mm)

## 6: Seat layout - Lateral split

Recommended lateral seat c-c measure is 600+ mm. (min 550 mm)

## 7: Tracks

A lateral c-c measure of 300 mm is the most compatible for Ullman Jockey seats.

## 8: Wheel position

For optimal operational ergonomics, place the wheel with a 45° (35-50°) vertical angle with an offset lateral position of 70 mm (compared to seat centre). This gives a symmetrical grip between the wheel and throttle and an upright seating position.

## Maintenance:

### Functional

No maintenance needed.

### Aesthetic

Fresh water rinse after usage.

For longest aesthetic life time, always use seat protection covers (included) when not in use or "stay on" Cordura covers (optional accessory).

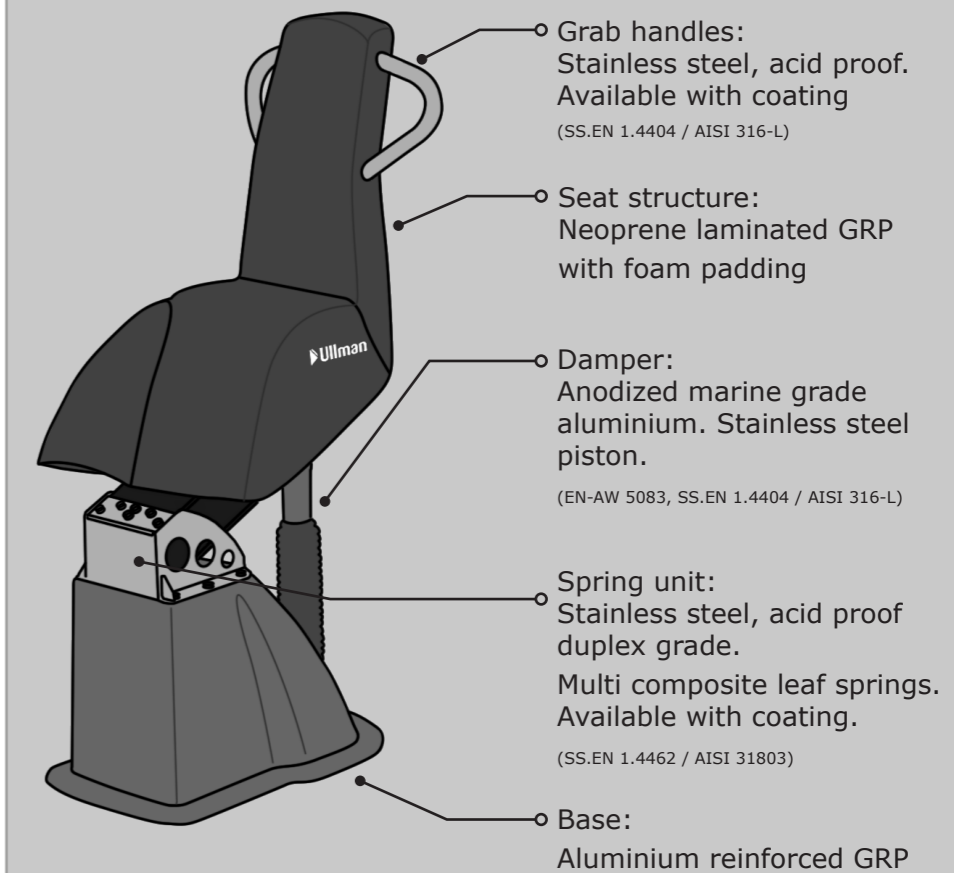

### Disclaimer

Driving fast at sea is always associated with significant risks, especially in high sea states. Even the best seats in the world will never be a guarantee against injuries. The enhanced control and comfort of the Ullman Jockey Seats and the Ullman Cockpit System can make you want to drive faster. Do not drive your boat faster than what feels comfortable for everyone on-board. It is your responsibility as a boat driver to keep everybody on-board safe.

### REMEMBER:

Discomfort is a sign of dangerous exposure. Pain is a sign of threatening injury.

# All you need to know - Ullman Jockey seats

install - use - maintain

**MK2 Square base**

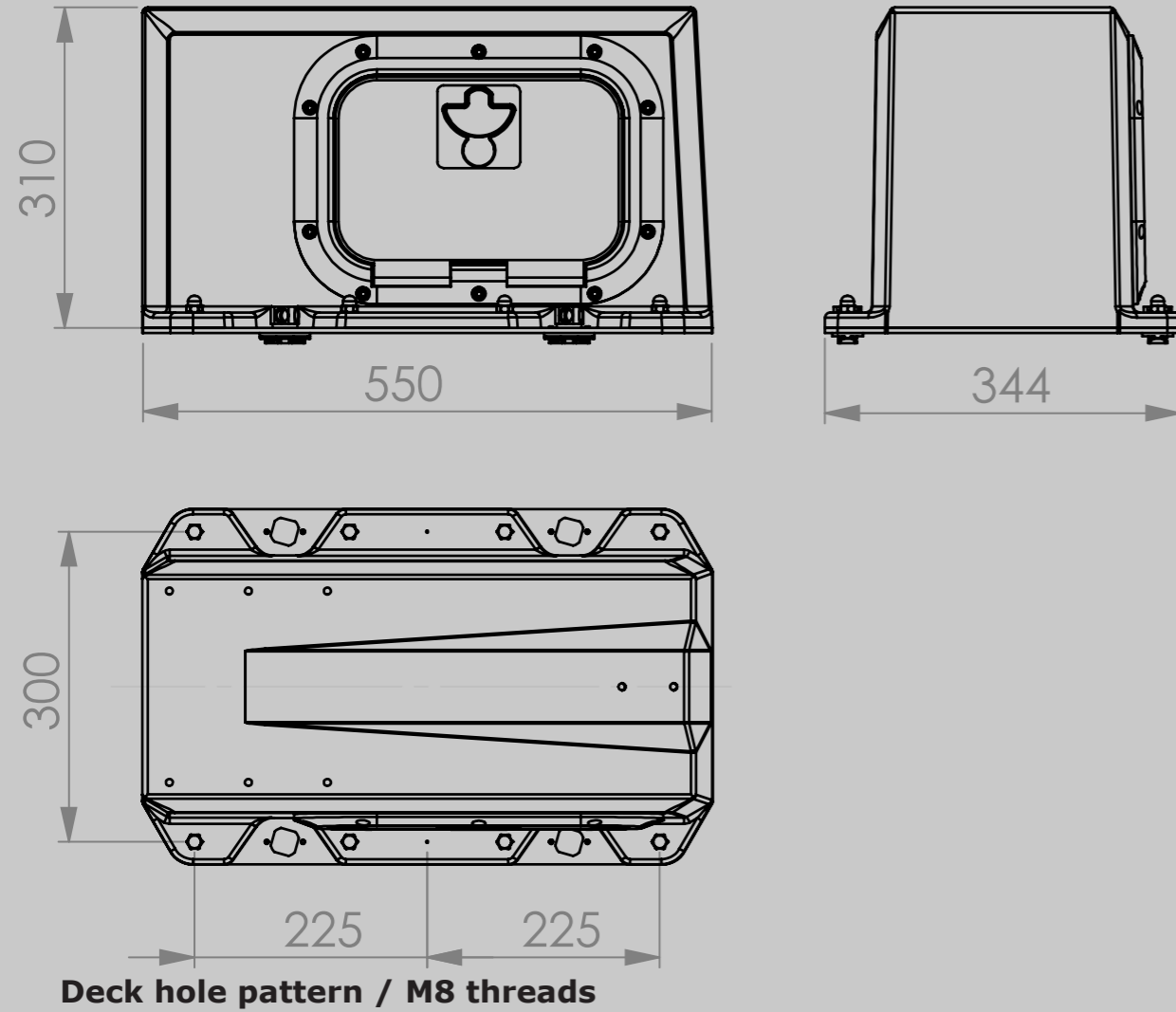

**MK1 base**

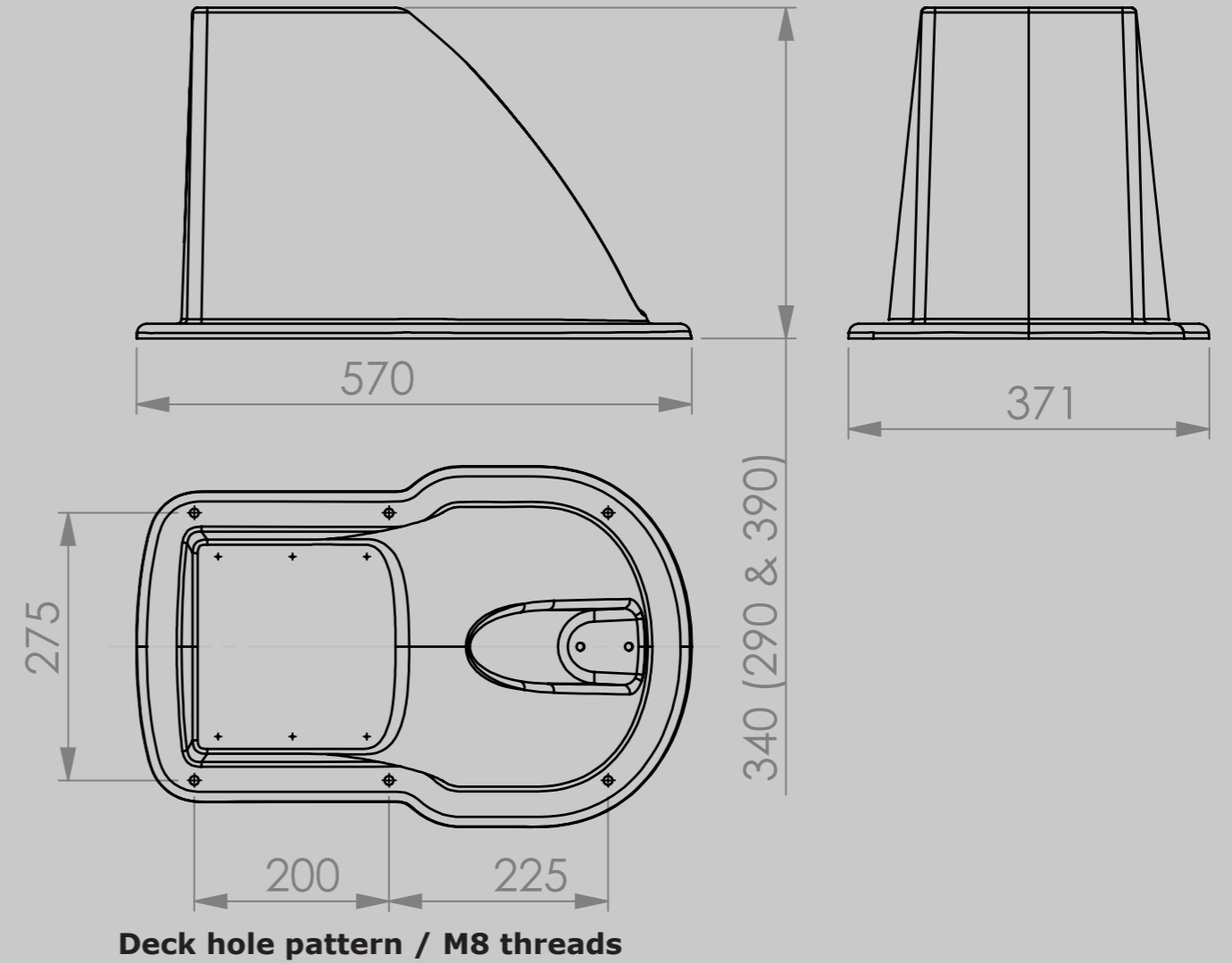

**00-series footprint - for custom base**

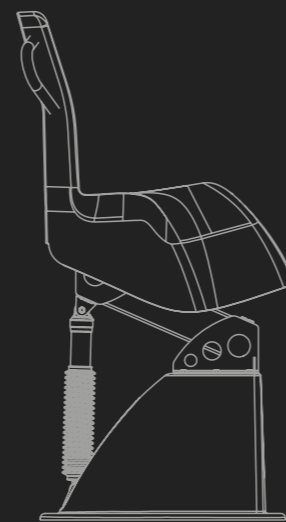
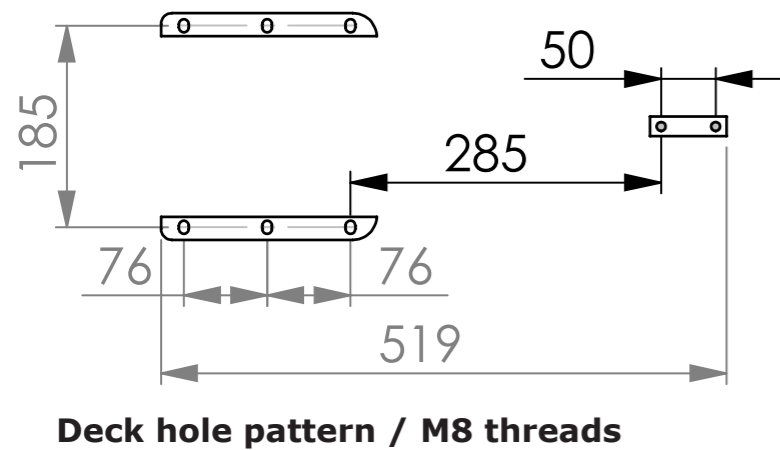

01 Series - MK1 base  
(Low damper placement)

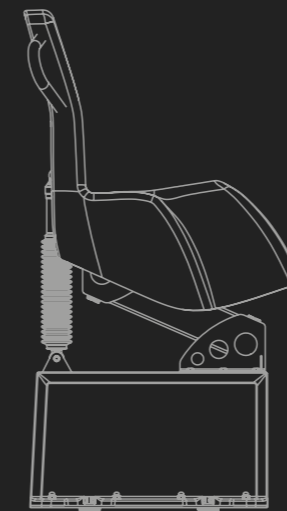

00 Series - MK2 base  
(Flat damper placement)

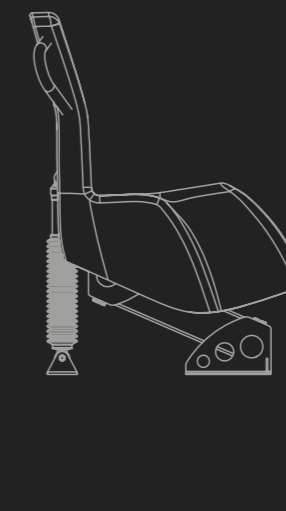

00 Series - Custom base  
(Flat damper placement)

